

ELECTRICAL CONNECTION

208-240V
 L1 - LINE
 N - NEUTRAL
 G - GROUND

400V
 L1/L2/L3 - LINE
 N - NEUTRAL
 G - GROUND

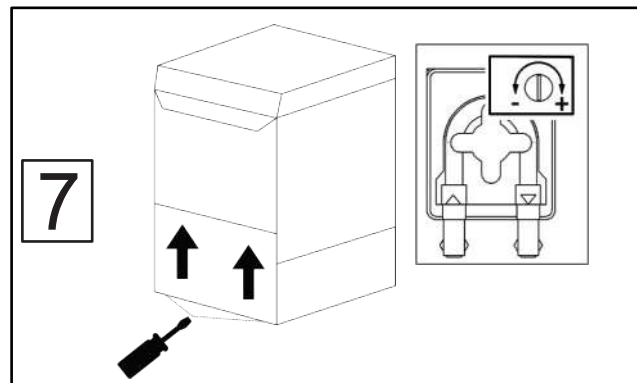

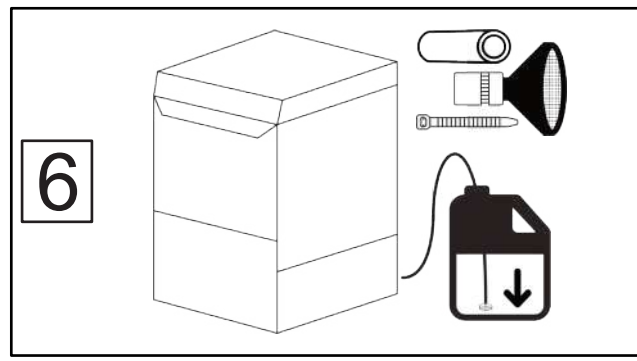
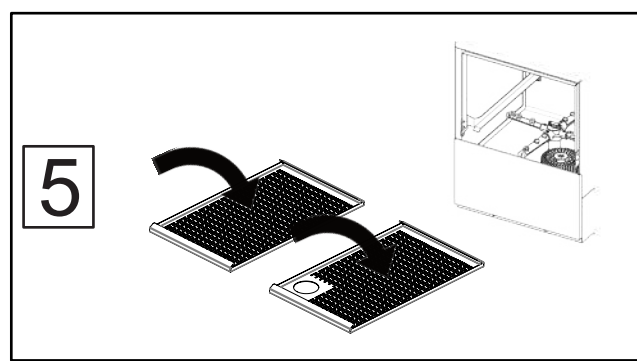
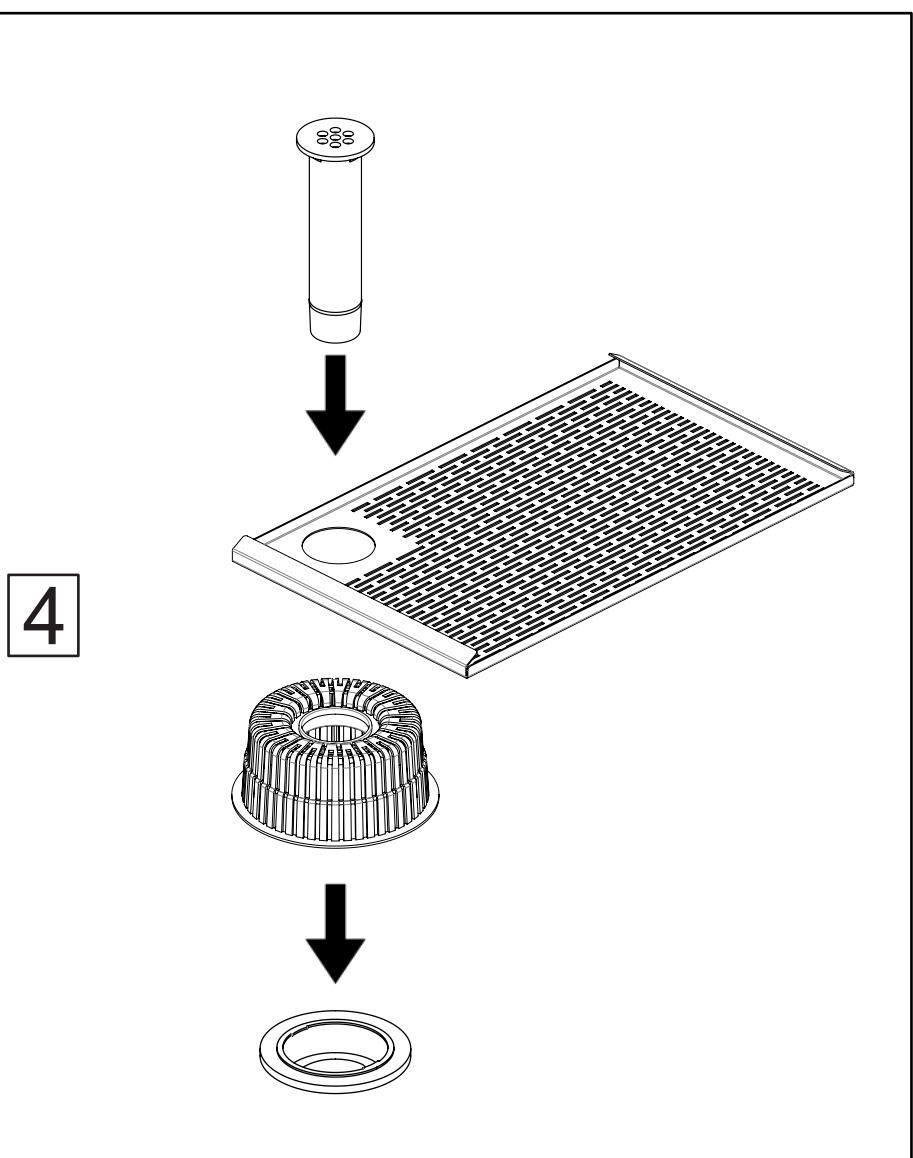
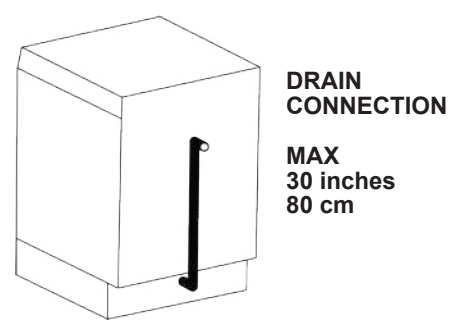
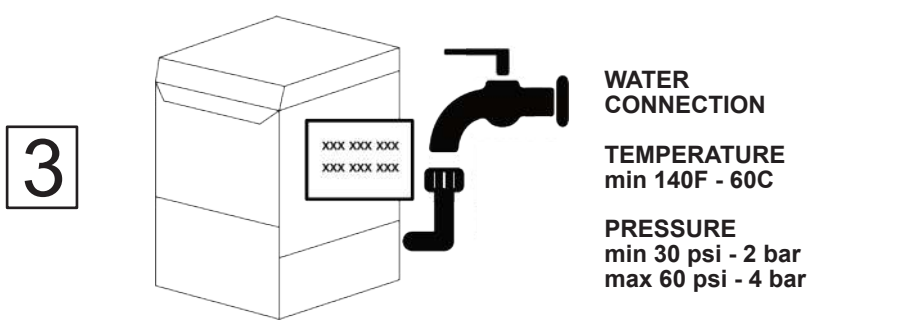
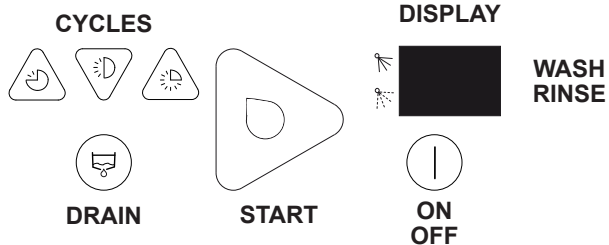
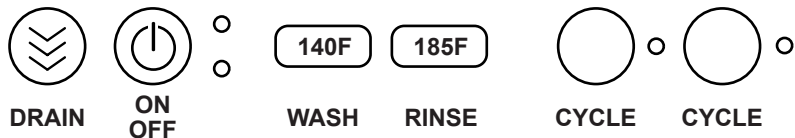

1



ON
OFF

WATER
FILLING



READY

2

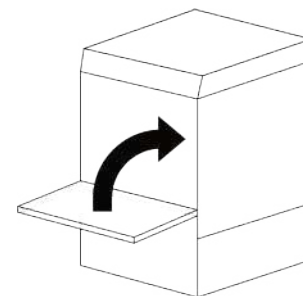
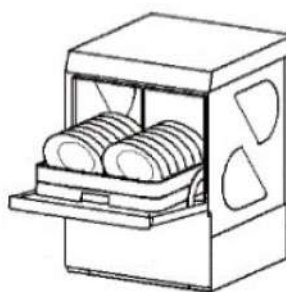
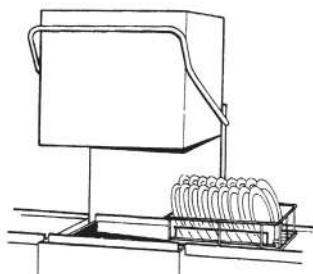
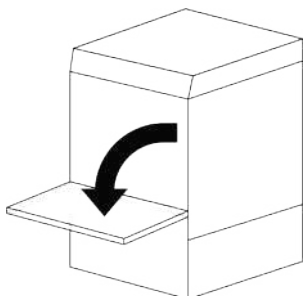

3

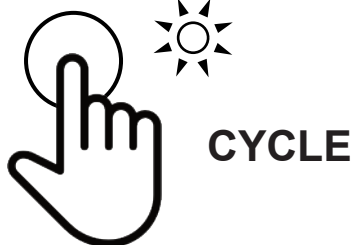

CYCLE

FINISH

4

CAUTION
OPEN DOOR
SLOWLY

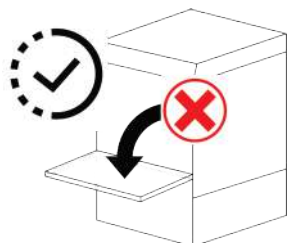

5

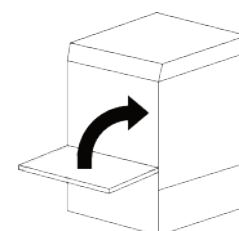
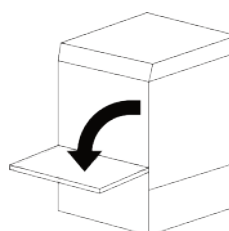

6



DRAIN

WATER
DRAIN



ON
OFF